

# OpenTouch™ Business Edition OpenTouch™ Multimedia Services

8068 Premium DeskPhone

8038 Premium DeskPhone

## User Manual

R220

8AL90317ENACed01-1620



## Introduction

This document describes the services offered by Premium DeskPhone connected to an OpenTouch™ Business Edition or OpenTouch™ Multimedia Services system.

This model offers enhanced ergonomical features for more effective communication.

- Alcatel-Lucent 8068 Bluetooth® Premium Deskphone (8068 BT).
- Alcatel-Lucent 8068 Premium Deskphone.
- Alcatel-Lucent 8038 Premium Deskphone.

Some features are depended on the type of the set.

	8068 BT	8068	8038
IP Phone	✓	✓	✓
Color screen	✓	✓	
Monochrome screen			✓
Bluetooth® Headset	✓		
Two-port Gigabit Ethernet switch with Power Over Ethernet support	✓	✓	✓
Add-on module	✓	✓	✓
Audio services (hands-free, handset and headset)	✓	✓	✓
Premium Smart display 14 keys module	✓	✓	✓
Adjusting the contrast of the display			✓
Phone screensaver	✓	✓	✓
Agent set / Supervisor station	✓	✓	✓

The labels and icons displayed on the phone depend on the type of the set.

The labels and icons come from the 8068 Premium Deskphone. 8038 Premium DeskPhone has black and white similar icons.

The labels and icons presented in this document are not contractually binding and may be modified without prior warning.

<b>1</b>	<b><u>GETTING TO KNOW YOUR TELEPHONE.....</u></b>	<b>5</b>
1.1	8068 BLUETOOTH® / 8068 PREMIUM DESKPHONE.....	5
1.2	8038 PREMIUM DESKPHONE .....	5
1.3	CONNECTIVITIES .....	6
1.4	HOMEPAGE SCREEN .....	6
1.5	CONTACT CARD .....	7
1.6	MEETING CARD .....	8
1.7	NAVIGATION .....	9
1.8	CALL ICONS .....	9
1.9	PERMANENT FEATURES KEYS .....	10
1.10	ALPHABETIC KEYBOARD.....	10
1.11	BLUETOOTH® WIRELESS HANDSET .....	11
1.12	ADD-ON MODULE .....	12
<b>2</b>	<b><u>CONTACTS MANAGEMENT.....</u></b>	<b>14</b>
2.1	LOCAL DIRECTORY AND FAVORITES .....	14
2.2	ADD A NEW CONTACT .....	15
2.3	DELETE A CONTACT .....	15
<b>3</b>	<b><u>USING YOUR TELEPHONE .....</u></b>	<b>16</b>
3.1	INFORMATION ABOUT THE PHONE .....	16
3.2	MANAGE THE CALL LOG.....	16
3.3	CALLING BY NUMBER .....	17
3.4	CALLING BY NAME .....	18
3.5	CALL FROM CALL LOG.....	18
3.6	MAKE A CALL USING THE LOCAL DIRECTORY .....	18
3.7	RECEIVING A CALL .....	19
3.8	USING THE TELEPHONE IN 'HANDS FREE' MODE .....	19
3.9	REDIALING .....	20
3.10	SENDING DTMF SIGNALS .....	20
3.11	MUTE, SO THAT YOUR CALLER CANNOT HEAR YOU.....	20
3.12	USE OF THE BLUETOOTH® HANDSET .....	21
<b>4</b>	<b><u>DURING A CONVERSATION.....</u></b>	<b>22</b>
4.1	MAKING A SECOND CALL DURING A CONVERSATION .....	22
4.2	ANSWERING A SECOND CALL DURING A CONVERSATION .....	22
4.3	SWITCHING BETWEEN CALLS (BROKER CALL) .....	23
4.4	TRANSFERRING A CALL .....	23
4.5	THREE-WAY CONFERENCE WITH INTERNAL AND/OR EXTERNAL CALLERS (CONFERENCE) .....	24
4.6	TALK SIMULTANEOUSLY TO MORE THAN 2 CALLERS .....	25
4.7	PLACING A CALL ON HOLD .....	25
4.8	ADJUST AUDIO VOLUME .....	25

<b>5</b>	<b><u>KEEP IN TOUCH</u></b> .....	<b>26</b>
5.1	ROUTING YOUR CALLS.....	26
5.2	OVERFLOW TO A NUMBER OR VOICEMAIL.....	27
5.3	LISTEN TO YOUR VOICEMAIL.....	27
<b>6</b>	<b><u>PROGRAMMING YOUR TELEPHONE</u></b> .....	<b>28</b>
6.1	ADJUSTING THE AUDIO FUNCTIONS.....	28
6.2	ADJUST RINGER VOLUME WHILE A CALL ARRIVES.....	29
6.3	SELECTING LANGUAGE.....	29
6.4	ADJUSTING THE CONTRAST OF THE DISPLAY (8038).....	29
6.5	PHONE SCREENSAVER.....	29
6.6	IDENTIFY THE TERMINAL YOU ARE ON.....	29
6.7	HIDE YOUR PHONE NUMBER.....	29
6.8	REBOOT YOUR PHONE.....	30
6.9	UPDATE THE CONFIGURATION OF YOUR PHONE.....	30
6.10	INSTALLING A BLUETOOTH® WIRELESS TECHNOLOGY HANDSET (MATCHING).....	30
6.11	INSTALLING A BLUETOOTH® DEVICE.....	30
6.12	REMOVE A BLUETOOTH® DEVICE.....	31
6.13	CONSULT YOUR PAIRED BLUETOOTH® DEVICES.....	31
6.14	CONSULT YOUR BLUETOOTH® PARAMETERS.....	31
<b>7</b>	<b><u>MANAGER/ASSISTANT</u></b> .....	<b>32</b>
7.1	MANAGER/ASSISTANT.....	32
7.2	SELECT AND ACTIVATE THE FILTERING MODE BETWEEN THE MANAGER AND ASSISTANT PHONES.....	33
<b>8</b>	<b><u>GUARANTEE AND CLAUSES</u></b> .....	<b>35</b>
8.1	SAFETY INSTRUCTIONS.....	35
8.2	REGULATORY STATEMENTS.....	36

# 1 Getting to know your telephone

## 1.1 8068 Bluetooth® / 8068 Premium Deskphone









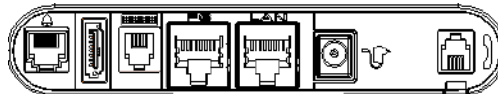

## 1.2 8038 Premium Deskphone



### 1.3 Connectivities

Description of the connectors:



- |  |  |
|--|--|
| <ul style="list-style-type: none"> <li> RJ 11 connector for external ringer and audio active envelop indicator.</li> <li> Add-on module connector (SATA type).</li> <li> RJ 9 connector for alphanumerical keyboard.</li> <li> 10/100/1000 Gigabit Ethernet connector (PC).</li> </ul> | <ul style="list-style-type: none"> <li> 10/100/1000 Gigabit Ethernet connector (LAN).</li> <li> DC power jack for an external power adaptor.</li> <li> RJ9 connector for a corded handset.</li> </ul> |
|--|--|

### 1.4 Homepage screen

The homepage shows the history of all your conversations.

The homepage screen comprises a title bar with information such as date and time and a main screen dedicated to the call log. The keys located on the left or right side of the screen are used to display the contact call log details and call back the contact respectively.



In idle state, the call log icon is displayed on the title bar and can be in different states.



There are no unacknowledged missed calls or unheard voice messages.



There is at least one unacknowledged missed call or unheard voice message (8068).

Use the right navigation key to navigate in the title bar.



Displays the number of unacknowledged missed calls (if there are any missed calls) (8068).



Access the routing and overflow configuration.



Access the local directory.



Access the voicemail. The number of new voice messages is displayed. The number of new voice messages is displayed.



Access the settings.



Access Manager/Assistant feature.

## 1.5 Contact card





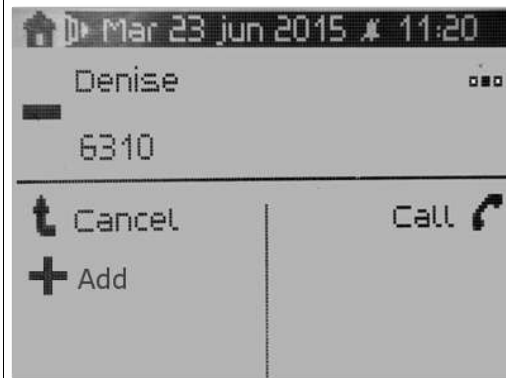
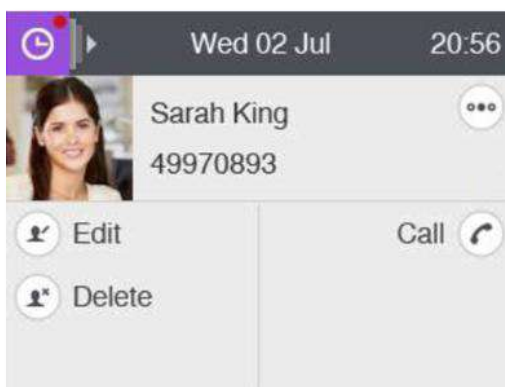

A contact card represents a person.

Open a contact card by selecting the left key.



A card contains 3 pages.

- Your conversation history with this contact.
- Main information about your contact (photo, phone number, email).
- Action proposed with this contact (call, add to local directory).

	Navigate between different pages.
	Call your contact.
	Go back to the Homepage.
	Add a contact to your local directory.
	Modify the contact.
	Delete a contact from your list of contacts.

## 1.6 Meeting card

A meeting card represents a group of persons (Conference).  
Open a contact card by selecting the associate and the left key.

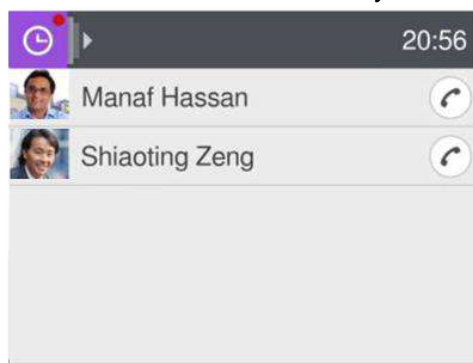

The meeting card lists all participants of the conference. From the list you can also open the contact card of a participant.

	Call your contact.
---	--------------------



## 1.7 Navigation



**OK key:**

- Short press  
Use to validate your choices and options while programming or configuring.
- In idle state  
Used to access features for managing the call log such as delete a log, delete all logs, display missed calls only and acknowledge missed calls.

**Left-right navigator:**

Use to move from one page to another and display information about current calls (call in progress, calls on hold, incoming call).

**Right navigator:**

Used to access features for configuring the phone or managing calls.

**Up-down navigator:**

When information extends over more than one page, use the down navigation key to display the next page. Use the up navigation key to display the previous page.



**Back/Exit key:**

Use this key to go back to the previous step.

Use this key to go back to the homepage (long press).

## 1.8 Call icons

Icons giving information about some specific configurations of the phone or about call status are displayed in the top bar of the screen.



Incoming call icon.

This icon blinks when there is another incoming call.



Call in progress icon.



Call holding icon This icon blinks when there is another ongoing call.



Conference.











The caller ended the conversation.



Search for a contact in the Company's directory.

## 1.9 Permanent features keys

They are located just above the loudspeaker.

	<b>Mute key</b> During a call, press this key to stop your contact from hearing you.
	Turn down the volume of the handset, loudspeaker or ringtone for incoming calls.
	
	Pressing this key answers an incoming call in handsfree mode (the key is blue). When a call is in progress, pressing this key switches from handsfree mode to headset or handset mode.
	<b>Line keys</b> Can be used to answer to an incoming call or switch from one call to another.
	Redial last number.
	Information about the user: lastname, firstname, phone number,...
	Displays information about the phone, the routing profile and the number of missed calls and new messages. This key blinks when you have received a new voice message or if you missed a call.

## 1.10 Alphabetic keyboard







Your set is provided with an alphabetic keyboard depending on your country and language:

- Country variants:
  - AZERTY
  - QWERTZ
  - QWERTY (international)
  - QWERTY (nordic)



Use the keyboard to enter names while configuring the phone. Directly access the dial by name feature by entering the name of your caller on the keyboard.

Below is a list of the function keys that allow you to access all the symbols.

	Cursor moving keys (left, right, up and down). Allows you to navigate edit boxes. Press the Alt key to access the left and up directions.
	
	Caps lock: to write text in capital letters.
	Alt key: to access specific and punctuation characters.
	Enter key: to validate edited text.
	Backspace key: to delete one character in an edit box.

## 1.11 Bluetooth® Wireless handset

The Bluetooth® Wireless handset is only available with the 8068 Bluetooth® Premium Deskphone.



If the Bluetooth® handset is on its base, you do not need to press the Off-hook/On-hook key to take or terminate the call. Just off-hook/on-hook the Bluetooth® handset.

### LED

- Off: operating normally.
- Green flashing: in communication.
- Green steady: handset charging.
- Orange flashing: battery charge low or handset outside coverage zone.
- Orange steady: malfunction.

### Installing or replacing the Bluetooth® handset battery

- ① Lift up the battery cover.
- ② Slide out the battery holding part.

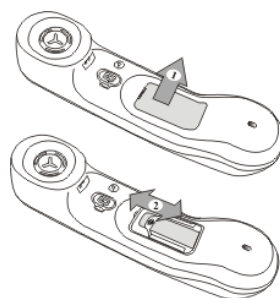

The battery recharges when the Bluetooth® handset is on its base.

## 1.12 Add-on module

Phone capabilities can be extended with Add-ons:



Premium Smart Add-on



Premium Add-on 40

### Attach the add-on with the clip

You can attach the base (set and add-ons) with the add-on clip, which is available as an option in pack.

#### Premium Smart Add-on

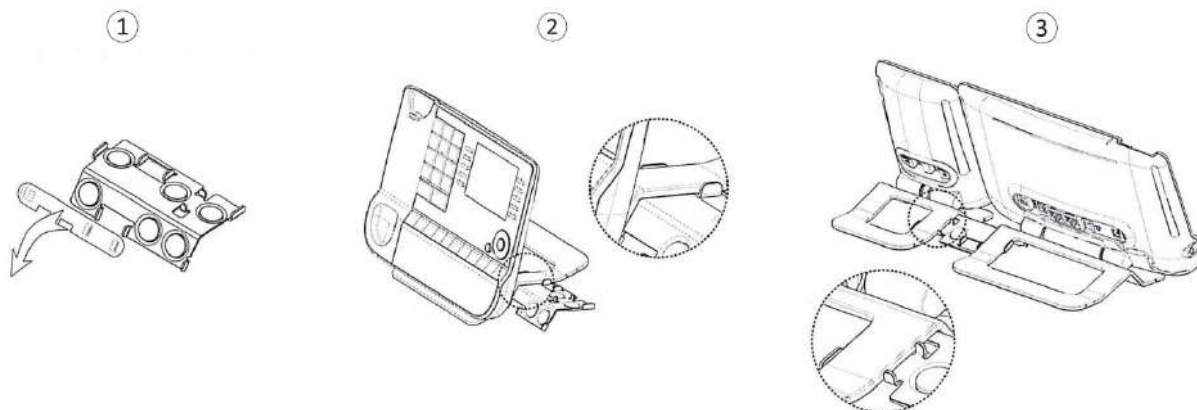

1 Remove the protection on the add-on clip

2 Place the clip in the correct position under the base of the phone, as shown in the image

3 Place the add-on onto the clip, as shown in the image

#### Premium Add-on 40

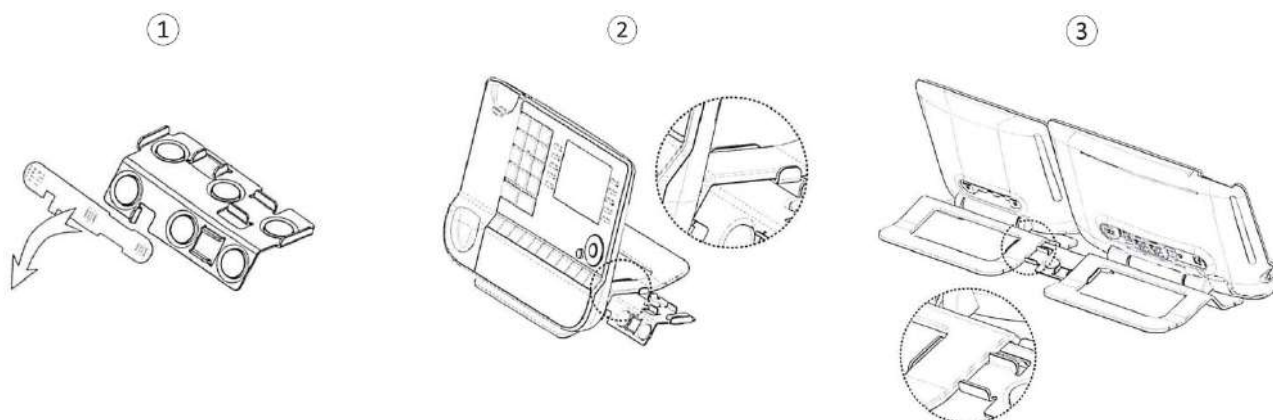

1 Remove the protection on the add-on clip

2 Place the clip in the correct position under the base of the phone, as shown in the image

3 Place the add-on onto the clip, as shown in the image

**Use the same procedure to attach an add-on to another add-on.**

## Connect the add-on

- A. Plug the cord provided into the dedicated sockets behind your set and the add-on.
- B. To connect another add-on, plug the new add-on into the one that is already connected using the dedicated sockets behind the add-ons and the cord provided.

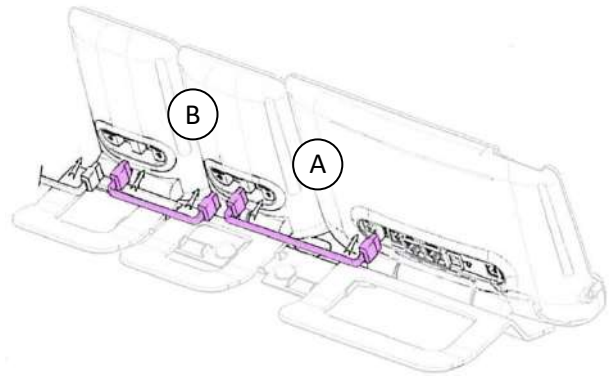



You can attach one or more add-ons to your phone. To attach another add-on, affix and connect the new add-on to the one that is already connected.



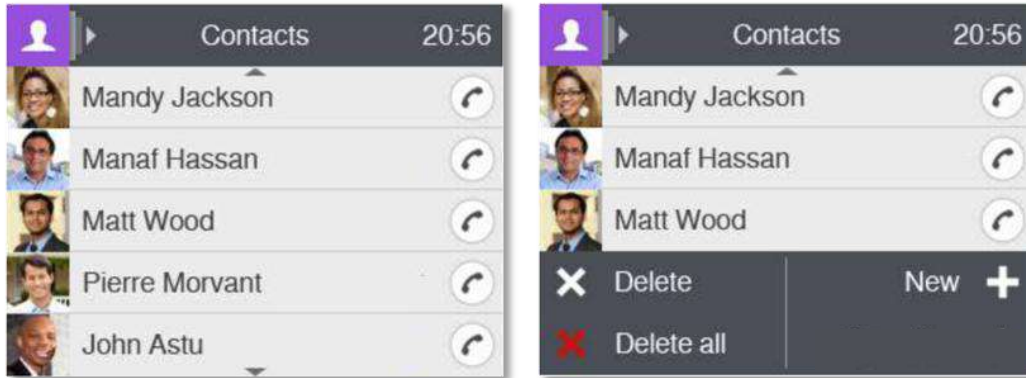

## 2 Contacts management



### 2.1 Local directory and favorites

Your phone lets you manage contacts in your local directory. Favorites give you faster access to your preferred contacts.



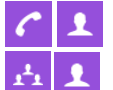

-  Use the right navigation key to open your local directory.
-  Press ok key to open menu.

	Create a new contact.
	Display all contacts in your local directory.
	Delete the selected contact.
	Delete all contacts in the local directory.

		During a conversation, you can open your local directory by using the right navigation key to consult it or to make a new call. The conversation key will be blinking (  ,  ). Select the conversation key to go back to the conversation page.
---	---	---



## 2.2 Add a new contact

If your local directory is empty, press the ok key to add a new contact.



- Use one of the following:
  - Add a contact from the call log (Contact card).
  -  Search for a contact in a corporate directory and add the selected contact in your local directory (Contact card).
  -  Create a new contact.  
Fill in the contact file.  
You must provide at least a last name.
  -  Choose a predefined avatar (8068).
- Your contact is added to the directory.

For external numbers, we recommend you use canonical address formats comprising '+', followed by the country code (e.g. '33') then the number without the first digit. For example, for 0390670000, enter the number +3390670000. To get the '+' sign, long press on the '0' key. This example is for calling a number in France from another country.

## 2.3 Delete a contact

-  Use the right navigation key to open your local directory.
-  Press the 'delete' key.

### Delete all contacts in the local directory

-  Press ok key to open menu.
-  Delete all.



## 3 Using your telephone

### 3.1 Information about the phone

-  Select this key to display information about the phone such as name, number, active routing profile, number of missed calls and new messages.





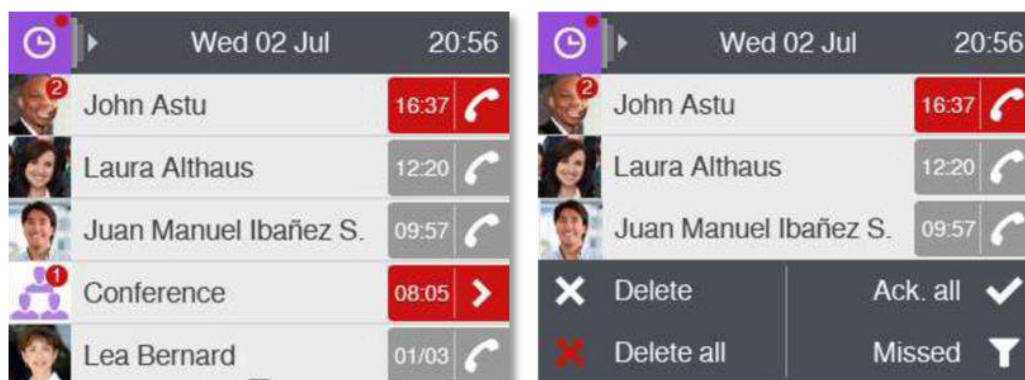









### 3.2 Manage the call log

The call log can be consulted and managed when the phone is in the idle state. The main part of the screen is used to display the call log.







#### Left keys – To open the contact card

Pressing the left key associated with a log will display all call logs associated with the selected contact.

8068	8038	
		Answered incoming calls.
		Unanswered incoming calls.
		Answered outgoing calls.
		Unanswered outgoing calls.
		Go back to the Homepage.
		Press the call key to call back the selected contact.
		Navigate between different pages.
		Display additional pages of the call log details if necessary.

#### Right keys – To call back the contact

Press the call log key to call back the contact. The associated icons can be grey or red.

8068	8038	
		This icon means the call was answered.
		This icon means the call was not answered (missed call).







#### Down navigation key – To display additional pages of the call log

Displays the next pages of the call log if needed (if call log contains more than 5 contacts).







### OK key – To manage the call log

Allows management of the call log by deleting filtering and acknowledging logs.





-  Press the delete key to delete specific logs.
  -  All call logs are displayed on the screen.
  -  Press the 'delete' key.
-  Press the key associated with the 'delete all' icon to delete all call logs. Please note that no confirmation is required before deletion.
-  Press this key to display missed calls only.
-  Press this key to acknowledge all missed calls.

 From the page containing information about the phone, you can open missed calls by selecting the number of missed calls.

		During conversation, you can open the call log by using the right navigation key to consult it or to make a new call. The conversation key will be blinking (  ,  ). Select the conversation key to go back to the conversation page.
---	---	---

### 3.3 Calling by number



Before dialing you can lift the receiver and press the on-hook/off-hook key (on the Bluetooth handset) or press the handsfree key and follow the below instructions.

-  Dial the number.
- Use one of the following:
  -  Press the OK key to start the call.
  -  Press the call key.
  -  Press the call icon key. This icon is only displayed when the number is recognized.

To make an external call, dial the outside line access code before dialing your contact number.

### 3.4 Calling by name

You can call a contact by their name using the search feature in the company directory.

-  Enter the first letters of the surname and/or firstname (or full name), or the initials of the surname and/or firstname.
-  Press the search key or the OK key to start the search by name.  
» All matching names are displayed on the screen (if necessary use the up and down navigation keys to display additional pages of matching names).
-  Call the contact by pressing the call icon key.  
» The call is started.



### 3.5 Call from call log

You can call back a contact from the call log.

When on the Homepage.









- Using the up and down navigator (if necessary), find the contact to call.
-  Press the relevant callback key in the call log (light grey for answered calls, red or black for unanswered calls).

### 3.6 Make a call using the local directory

-  Use the right navigation key to open your local directory.
-  Call the contact by pressing the call icon key.  
» The call is started.
- If there are several numbers for the same contact, select the desired number.





### 3.7 Receiving a call

When receiving a call, you can:





- Lift the receiver to take the call.
-  /  /  Press the 'take the call', 'loudspeaker' or 'line key' key to take the call in handsfree mode.
-  Press the On-Hook/Off-Hook key on the Bluetooth handset to take the call (if handset is not on-hooked) - (Bluetooth® Wireless handset).
-  Mute the ringer (the call is still incoming but the phone no longer rings).
-  Deflect the call to another contact:
  - Enter the number or name of the contact to whom the call will be deflected.
  -  Call the contact by pressing the call icon key.
-  Deflect the call to your voicemail.
-  Deflect the call to the personal assistant.

### 3.8 Using the telephone in 'Hands free' mode

**Terminal idle:**

-  /  /  Press the 'take the call', 'loudspeaker' or 'line key' key to take the call in handsfree mode >> You are in hands free mode.
-  Terminate your call.

**Call in progress:**

- During a conversation.
-  Press and release.
- >>  You are in hands free mode.
-  Press and release.
- >>  You are no longer in hands free mode.

During a conversation, you can on-hook the handset without ending the call.

### 3.9 Redialing

#### Redialing the last number dialed (redial)

-  >> Last number redial.

### 3.10 Sending DTMF signals

Sending DTMF is subject to configuration. Contact your administrator to check that the feature is enabled.

During a conversation you sometimes have to send DTMF signals, such as with a voice server, an automated attendant or a remotely consulted answering machine.



- During a conversation.
-  Enter DTMF code.

The function is automatically cancelled when you hang up.



### 3.11 Mute, so that your caller cannot hear you

You can hear your caller but he/she cannot hear you:

#### From the set

- During a conversation.
-  Disable microphone >> The mute key blinks.
-  Resume the conversation >> The mute key no longer blinks.

#### From the Bluetooth® receiver (Bluetooth® wireless handset)

-  Press the handset volume/mute key (long press) >> The mute key blinks.
-  Press the handset volume/mute key (long press) >> The mute key no longer blinks.

### 3.12 Use of the Bluetooth® handset

The Bluetooth® Wireless handset is only available with the 8068 Bluetooth® Premium Deskphone.



The Bluetooth® cordless handset permits the user to answer and converse with complete freedom within a radius of 10 meter from the set.

The handset has a LED and two buttons.

#### Light:

- Green flashing: normal operation.
- Green steady: handset charging.
- Orange flashing: battery charge low or handset outside coverage zone.
- Orange steady: malfunction.

#### Off-hook/On-hook and Volume/Mute keys:







-  Off-hook/On-hook: press this key to take or terminate a call.
-  Volume/Mute:
  - Short successive presses to change the handset volume level (3 levels).
  - Long press to ensure your caller no longer hears you.

If the Bluetooth® handset is on its base, you do not need to press the Off-hook/On-hook key to take or terminate the call. Just off-hook/on-hook the Bluetooth® handset.

## 4 During a conversation

### 4.1 Making a second call during a conversation

During a conversation.



-  Press the key associated with the icon: *New call*.
- Use one of the following:
  - Call your contact using the dial by name or the dial a number feature.
    -  Press the call icon key.
    - » The first call is on hold.
  -  Select the 'Redial' function.
    - » The first call is on hold.
  -  /  Open the call log or your local directory by using the right navigation key.
    -  Press the call icon key.
    - » The first call is on hold.



*Add*: add directly a second call to your conversation (conference).

#### To cancel your second call and recover the first:

You are in conversation with the second caller and the first one is on hold.

-  You or the second caller hangs up.
-  Press the key associated with the icon: *Retrieve*
  - » You are on the line with your first contact.

### 4.2 Answering a second call during a conversation



During a conversation, another person is trying to call you. You are alerted with 3 beeps. The identity of the caller is displayed as long as the call is presented on your phone.

-  Press the 'take the call' key.
  - » The first call is on hold.

As long as the call is presented, you can also choose to deflect the call.



### To cancel your second call and recover the first:

You are in conversation with the second caller and the first one is on hold.

-  You or the second caller hangs up.
-  Press the key associated with the icon: *Retrieve*.  
 >> You are on the line with your first contact.

## 4.3 Switching between calls (Broker call)



During a conversation, a second call is on hold.

- Use one of the following:
  - Press the blinking line key.  
 >> You can talk to the second caller and the first one is on hold.
  -  Using the left-right navigation keys, select the blinking 'call on hold' icon.  
 Press the key associated with the icon: *Retrieve*.  
 >> You can talk to the first caller and the second one is on hold.

## 4.4 Transferring a call

### To transfer your call to another number:

During a conversation.

-  Press the key associated with the icon: *Transfer*.  
 >> The first call is on hold.
-  Call the recipient of the transfer using the dial a number or dial by name feature or the call log or local directory.  
 >> The transfer is done as soon as the call is started.

Transfer between two outside calls is not generally possible (depends on country concerned and system configuration).

### To transfer a call to another caller on hold

During a conversation.

-  Press the key associated with the icon: *Transfer to*.  
 >> The two callers are connected.

## To transfer a call to another device

During a conversation.

-  Press the key associated with the icon: *Other Device*.
- Select the device to which to transfer the call.
  - » The call is transferred to the selected device.

## 4.5 Three-way conference with internal and/or external callers (conference)

During a conversation, a second call is on hold.

-  Press the key associated with the icon: *Conference*.
  - » You are in conference mode.



### Display the list of participants

You are in conference mode.

-  Press the key associated with the icon: *Participate list*.
  - » The list of participants is displayed.

### Cancel conference and return to one of the participants

You are in conference mode.

-  Press the key associated with the icon: *Participate list*.
  - » The list of participants is displayed.
-  Remove participant.  
You can remove a participant from the conference.
  - » You are on the call with the remaining participant.

### End the conference with all participants

You are in conference mode.

-  Press the key associated with the icon: *End conf*.
  - » The conference is ended.

### After the conference, to leave your two callers talking together:

You are in conference mode.

-  Press the on-hook key.
  - » The two participants remain on the call together.



## 4.6 Talk simultaneously to more than 2 callers



You are in a conversation with one or more callers. Add another caller to the conversation:

-  Press the key associated with the icon: *Add*.
- Call your contact using the dial by name or the dial a number feature.
  - » The new participant is automatically added to the conference as soon as the contact answers.

### Display the list of participants

-  Press the key associated with the icon: *Participate list*.
  - » The list of participants is displayed.



### Remove a participant from the conversation

-  Press the key associated with the icon: *Participate list*.
  - » The list of participants is displayed.
-  Remove participant.



## 4.7 Placing a call on hold

During a conversation, you wish to place the call on hold and recover it later, on the same telephone.

Place the call on hold:

-  Press the key associated with the icon: *Put on hold*.
  - » The call is placed on hold ().

Recover the call on hold:

-  Press the key associated with the icon: *Retrieve*.
  - » You can resume the conversation ().

## 4.8 Adjust audio volume

During a call, to adjust the volume level of the loudspeaker or receiver:

-   Adjust audio volume.

# 5 Keep in touch



## 5.1 Routing your calls

You can choose to route your calls to different destinations such as your voicemail, another user, or your office devices.



### Route your calls to your voicemail

-  Using the left-right navigator, select the routing and overflow profile configuration menu.
- Press the keys associated with: *Profile* > *Voicemail*.  
 >> Your calls are routed to voicemail.



### Route your calls to another number

-  Using the left-right navigator, select the routing and overflow profile configuration menu.
- Press the keys associated with: *Profile* > *User*.
-  Select the user to route the calls to using the dial a number or search by name feature.  
 >> Your calls are routed to the user.

### Route your calls to an office device

-  Using the left-right navigator, select the routing and overflow profile configuration menu.
- Press the keys associated with: *Profile* > *My office device*.
-  Display the list of devices.  
 >> Your calls are routed to the selected device

### Route your calls to a customized list of devices

-  Using the left-right navigator, select the routing and overflow profile configuration menu.
- Press the keys associated with: *Profile* > *Customized*.
-  Select a device to route calls to by pressing the associated key or entering another device number.  
 >> Your calls are routed to the selected device.



## 5.2 Overflow to a number or voicemail.

Your phone allows you to use default types of overflow.

-  Using the left-right navigator, select the routing and overflow profile configuration menu.
- Press the key associated with: *Overflow*.
- Pressing the associated key, select from:
  - *No Overflow*  
When selecting this option, overflow will not be activated.
  - *If no reply to voicemail*  
If you are absent your call will be diverted to voicemail.
  - *No Reply*  
If you are absent your call will be diverted to a number that you have pre-defined.
  - *If busy/no reply to voicemail*  
If you are absent or busy, any callers are diverted to voicemail.
  - *Busy/No Reply*  
If you are absent or busy, any callers are diverted to a different phone number that you have defined.

## 5.3 Listen to your voicemail



The message key flashes when you have received a new voicemail or if you have missed calls.

- Use one of the following:
  -  Press the messaging key.  
Press the new voice message key.  
Follow the instructions from the voicemail server.
  -  Using the left-right navigator keys, select the voicemail menu.  
Press the voicemail key.  
Follow the instructions from the voicemail server.
-  Customize your voice mail.





# 6 Programming your telephone

## 6.1 Adjusting the audio functions



### Select the melody

-  Using the left-right navigator keys, select the settings menu.
- Press the keys associated with: *Phone* › *Ringling* › *Melody*.
- Select the melody of your choice (16 tunes).
-  Press the OK key to validate your choice.



### Adjusting the ringer volume

-  Using the left-right navigator keys, select the settings menu.
- Press the keys associated with: *Phone* › *Ringling* › *Level*.
-   Select the volume you want (9 levels).
-  Press the OK key to validate your choice.



### Configure the ringtone

-  Using the left-right navigator keys, select the settings menu.
- Press the keys associated with: *Phone* › *Ringling* › *Ringling mode*.
- Pressing the associated key, select from:
  - *Normal ringing*  
A normal ring signals an incoming call.
  - *Silent mode*  
The phone no longer rings. The LED flashes to signal an incoming call.
  - *Progressive Ringing*  
A progressive ring signals an incoming call.
-  Press the OK key to validate your choice.



### Configuring discreet mode (beep)

-  Using the left-right navigator keys, select the settings menu.
- Press the keys associated with: *Phone* › *Ringling* › *Beep*.
- Pressing the associated key, select from:
  - *1 beep before ring*  
A beep followed by the ring signals an incoming call.
  - *3 beep before ring*  
Three beeps followed by the ring signals an incoming call.
  - *Ring without beep*  
A normal ring signals an incoming call.
-  Press the OK key to validate your choice.



## 6.2 Adjust ringer volume while a call arrives

- Your telephone rings.
-   Adjusting the ringer volume.
-  Press the OK key to validate your choice.

## 6.3 Selecting language

-  Using the left-right navigator keys, select the settings menu.
- Press the keys associated with: *Phone* > *Language*.
- Select the language of your choice.
-  Press the OK key to validate your choice.

## 6.4 Adjusting the contrast of the display (8038)

-  Using the left-right navigator keys, select the settings menu.
- Press the keys associated with: *Phone* > *Contrast*.
-   Adjust contrast.

## 6.5 Phone screensaver

-  Using the left-right navigator keys, select the settings menu.
- Press the keys associated with: *Phone* > *Screen saver*.
- Enable screensaver and define the delay.

## 6.6 Identify the terminal you are on

-  >> The name and number of your phone are displayed.

## 6.7 Hide your phone number

You can choose to hide your identity when calling.

-  Using the left-right navigator keys, select the settings menu.
- Press the keys associated with: *Phone* > *Anonymous*.
- Select the option: *Anonymous*  
>> Your identity will be hidden.

## 6.8 Reboot your phone

You might be requested by your system administrator to reboot your phone.

-  Using the left-right navigator keys, select the settings menu.
- Press the key associated with: *Reboot*.  
» Your phone reboots.



## 6.9 Update the configuration of your phone

You might be requested by your system administrator to update the configuration of your phone.

-  Using the left-right navigator keys, select the settings menu.
- Press the key associated with: *Config update*.  
» The configuration update process starts.

## 6.10 Installing a Bluetooth® Wireless Technology handset (matching)

This feature is only available with compatible Bluetooth® phone (8068 Bluetooth® Premium Deskphone). Otherwise the corresponding menu is not displayed or is inactive.

-  Using the left-right navigator keys, select the settings menu.
- Press the keys associated with: *Phone* » *Bluetooth* » *Add device*.  
» Scanning starts.
-  With the handset turned off, press the 2 Bluetooth® handset keys at the same time (long press).  
» You will hear a 3 note signal and the LED will flash green and orange alternately.
- Searching for Bluetooth® equipment. Wait for the detected equipment type and address to be displayed.
- Select the relevant device by pressing the associated key.
- Add the device by pressing on the associated key: *Add*.  
» The 3-note tone indicates that the handset has been installed correctly (the LED flashes green or orange depending on the battery charge level).

### Error messages

The Bluetooth® handset emits a sequence of 4 beeps.	»	Your set is an older generation than your Bluetooth® handset.
The set displays an error message indicating that the set and the Bluetooth® handset are incompatible.	»	Your Bluetooth® handset is an older generation than your set.

## 6.11 Installing a Bluetooth® device



This feature is only available with compatible Bluetooth® phone (8068 Bluetooth® Premium Deskphone). Otherwise the corresponding menu is not displayed or is inactive.

Before performing the matching operation, the device must be in detectable mode. Consult the user documentation of your Bluetooth device.

-  Using the left-right navigator keys, select the settings menu.
- Press the keys associated with: *Phone* › *Bluetooth* › *Add device*.  
›› Scanning starts.
- Searching for Bluetooth® equipment. Wait for the detected equipment type and address to be displayed.
- Select the relevant device by pressing the associated key.
- Add the device by pressing on the associated key: *Add*.
- Enter the PIN code of the device if necessary.

## 6.12 Remove a Bluetooth® device

You can uninstall a Bluetooth® device such as a handset from your phone.

-  Using the left-right navigator keys, select the settings menu.
- Press the keys associated with: *Phone* › *Bluetooth* › *My devices*.  
›› The paired devices are displayed.
- Select the device to be removed by pressing the associated key.
-  Press the 'remove' key.
- ›› Message acknowledging the equipment has been removed.

## 6.13 Consult your paired Bluetooth® devices

-  Using the left-right navigator keys, select the settings menu.
- Press the keys associated with: *Phone* › *Bluetooth* › *My devices*.  
›› The paired devices are displayed.

## 6.14 Consult your Bluetooth® parameters

-  Using the left-right navigator keys, select the settings menu.
- Press the keys associated with: *Phone* › *Bluetooth* › *BT paramtrs*.  
›› The Bluetooth® parameters are displayed.

# 7 Manager/Assistant

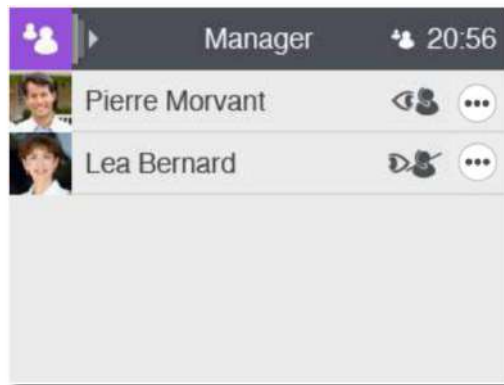

## 7.1 Manager/Assistant



The Manager/Assistant application offers specific additional features when the manager set is configured for use with an assistant phone.

	When manager/assistant is enable, an icon is displayed in title bar.
--	--



-  Use the right navigation key to open the manager assistant application.

A Long or short press of the right key lets you enable/disable manager/assistant or call your manager / assistant. The action for a long press or a short press is defined in settings. If necessary you may need to contact your administrator.

### Assistant station

- 
  -  Call your manager.  
If you are already on a call, the first caller is placed on hold.
  -  Enable Manager/Assistant filtering and call monitoring.

### Manager station

- 
  -  Call your assistant.  
If you are already on a call, the first caller is placed on hold.
  -  Enable Manager/Assistant filtering and call monitoring.



## Pick-up an incoming supervised call



-  To pick-up the call, press the corresponding key.

 When an incoming call arrives, the manager/assistant icon will start blinking. Press the corresponding key to open the manager assistant application. If the manager/assistant is not the current page, the call information is displayed on the title bar.



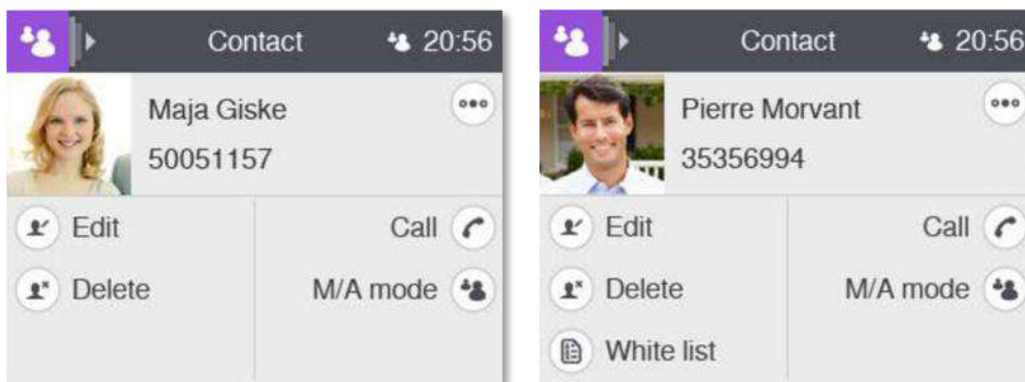

## 7.2 Select and activate the filtering mode between the manager and assistant phones

The filtering mode allows the assistant and the manager to choose how to route and monitor incoming calls to the manager.



- From the manager/assistant page, press left key to open the manager or assistant card.

-  Press on the Mode key.
- Select the filtering mode to activate:

-  *Assistant receive*
-  *Mgr. monitor/Asst. recv.*
-  *Mgr. recv./Asst. monitor*
-  *Off*
-  *Backup assistant*



### ***Assistant receive***

When a caller is calling the Manager set, the call is directly forwarded to the Assistant set if the caller is not a private caller (not registered on the 'White list'). A 'White list' is a set of callers that should not be routed to the assistant's phone when 'delegation' is active.

In this filtering mode, the manager is not notified of incoming calls routed to the assistant. The manager cannot pick up the incoming call. The manager can see the name of the caller in the history preview pane.



### ***Mgr. monitor/Asst. recv.***

When a caller is in conversation with the Managers phone, the Assistants phone is informed of the call if the caller is not a private caller (not registered in the 'White List') A 'White list' is a set of callers that should not be routed to the assistant's phone when 'delegation' is active.

Incoming calls to the Manager are routed to the assistant. The manager is notified of calls by ringing state only. This allows the manager to pick them up during the ringing state.

The assistant can see the name of the caller in the history preview pane.



### ***Mgr. recv./Asst. monitor***

In this filtering mode, the assistant is notified of the incoming call on the manager set. If necessary, the assistant can pick up the incoming call before the manager answers the call.



### ***Off***

The Manager/Assistant feature is deactivated. There is no routing and monitoring between the two phones.



### ***Backup assistant***

Activate/deactivate a temporary backup assistant. The main assistant can define a temporary backup assistant. This is to ensure you receive continuous service in case, for instance, the main assistant is not available. When selecting a backup assistant, the identity of the backup assistant is displayed on the manager's phone.

-  Deactivation of the backup assistant.

## 8 Guarantee and clauses

---

### 8.1 Safety Instructions

- Changes or modifications to the equipment not expressly approved by the party responsible for compliance could void the user's authority to operate the equipment.
- Magnets could affect the functioning of pacemakers and implanted heart defibrillators. Keep a safe distance between your pacemaker or implant defibrillator and the handset which includes magnetic elements: 4 centimeters (1,6 inches) at least.
- To limit the risk of interference, people with pacemakers must keep the wireless telephone away from their equipment (minimum distance of 15 cm/6 inches).
- It is recommended to follow the standard acceptance procedures before using this equipment in human safety critical areas (hospitals...).
- The handset includes magnetic elements that may attract sharp metallic objects. To prevent injury, before each use ensure sharp metallic objects are not stuck to the earpiece and microphone.
- There is a danger of explosion if the battery is replaced incorrectly - use only the battery with the reference 3GV28041AB (1.2V 1500 mAh) (Bluetooth® Handset only).
- Battery charge (Bluetooth® Handset only): Charge the battery for about 6 hours before initial use.
- Avoid using phones (other than cordless type) during an electrical storm. There may be a remote risk of electric shock from lightning.
- Do not use the device in environments where there is a danger of explosion.
- Do not plug this phone into an Integrated Services Digital Network (ISDN) connection or into a regular Public Switched Telephone Network (PSTN) connection. This can result in severe damage to the phone.
- Never allow your telephone to come into contact with water.
- To clean your telephone, use a soft damp cloth. Never use solvents (trichlorethylene, acetone, etc.) which may damage the plastic parts of your telephone. Do not use aerosol cleaners.
- This product is intended to be connected to the PABX via the LAN (10/100/1000 MB).
- If you are connected to a POE connection do not use an external Power Supply.
- The PoE (Power over Ethernet) devices that supply or receive power and their connected cables must all be completely indoors.
- The RJ45 jack is not used for telephone line connection.
- The 8068 Premium Deskphone also offers a Bluetooth® Radio Interface for the Bluetooth® handset or other Bluetooth® devices - frequency range 2402-2480 MHz, Radiated Power 1mW.

## 8.2 Regulatory Statements

### Marking

This equipment is in compliance with the essential requirements of Radio Equipment Directive (RED) 2014/53/EU and with Directive 2011/65/UE (ROHS).

The Declaration of Conformity may be obtained from:

ALE International 32 avenue Kléber – 92700 Colombes, France

[ebg\\_global\\_supportcenter@al-enterprise.com](mailto:ebg_global_supportcenter@al-enterprise.com)

### USA and Canada

This device complies with Part 15 of the FCC Rules and with RSS210 of Industry Canada. Operation is subject to the following two conditions: (1) this device may not cause harmful interference, and (2) this device must accept any interference received, including interference that may cause undesired operation.

### Exposure to Radio Frequency Signals.

This equipment complies with radiation exposure limits set by FCC/IC and the European Council. This equipment has very low levels of RF energy and is deemed to be compliant without testing of the specific absorption rate (SAR).

### User Instructions

Only use the handset in temperatures between 5°C to +45°C (23°F to 113°F). This product is intended for use in an indoor environment only. This apparatus is Hearing Aid Compatible (HAC).

### Acoustic shock protection

Maximum sound pressure level for handset is compliant with European, US and Australian standards.

### Directive 2003/10/EC specifying the risks inherent in noise at work

A wired handset is also available and can replace the Bluetooth® handset.

### Privacy

Privacy of communications may not be ensured when using the Bluetooth® handset or any additional Bluetooth® device.

### Disposal



The equipment must be returned to a collection point for electronic equipment waste disposal.  
Defective batteries must be returned to a collection point for chemical waste disposal.

### Related Documentation

Other languages for these Safety and Regulatory Instructions and User Documentation are available at the following Web site:

<http://www.al-enterprise.com?product=All&page=Directory>.

The labels and icons presented in this document are not contractually binding and may be modified without prior warning.

The information presented is subject to change without notice. ALE International assumes no responsibility for inaccuracies contained herein. Copyright© ALE International 2016.



**Features keys**

During a call, press this key to stop your contact from hearing you.	
Turn down the volume of the handset, loudspeaker or ringtone for incoming calls.	
Turn up the volume of the handset, loudspeaker or ringtone for incoming calls.	
Pressing this key answers an incoming call in handsfree mode (the key is blue). When a call is in progress, pressing this key switches from handsfree mode to headset or handset mode.	
Line keys Can be used to answer to an incoming call or switch from one call to another.	
Redial last number.	
Gives general information on the use of the navigation keys and some specific keys.	
Displays information about the phone, the routing profile and the number of missed calls and new messages. This key blinks when you have received a new voice message or if you missed a call.	

**Bluetooth® wireless handset (8068 Bluetooth® Premium Deskphone)**

	Off-hook/On-hook: press this key to take or terminate a call.	
	Volume/Mute: <ul style="list-style-type: none"> <li>Short successive presses to change the handset volume level (3 levels).</li> <li>Long press to activate or deactivate mute mode.</li> </ul>	

**Homepage screen**

The homepage screen comprises a title bar with information such as date and time and a main screen dedicated to the call log. The keys located on the left or right side of the screen are used to display the contact call log details and call back the contact respectively. The labels and icons come from the 8068 Premium Deskphone. 8038 Premium DeskPhone has grayed similar icons.

**Navigation**

	<b>OK key:</b> Use to validate your choices and options while programming or configuring. In idle state Used to access features for managing the call log such as delete a log, delete all logs, display missed calls only and acknowledge missed calls. <b>Left-right navigator:</b> Use to move from one page to another and display information about current calls (call in progress, calls on hold, incoming call). <b>Right navigator:</b> Used to access features for configuring the phone or managing calls. >  Routing >  Voicemail >  Settings >  Contacts
	<b>Up-down navigator:</b> When information extends over more than one page, use the down navigation key to display the next page. Use the up navigation key to display the previous page.
	Use this key to go back to the previous step. Use this key to go back to the homepage (long press).

**Call icons**





Icons giving information about some specific configurations of the phone or about call status are displayed in the top bar of the screen.

	Incoming call icon: This icon blinks when there is another incoming call.		Conference.
	Call in progress icon.		The caller ended the conversation.
	Call holding icon: This icon blinks when there is another ongoing call.		Search for a contact in the Company's directory.

**Alphabetic keypad**







Cursor moving keys (left, right, up and down). Allows you to navigate edit boxes. Press the Alt key to access the left and up directions.		
Caps lock: to write text in capital letters.		
Alt key: to access specific and punctuation characters.		
Enter key: to validate edited text.		
Backspace key: to delete one character in an edit box.		

### Local directory and favorites



- Use the right navigation key to open your local directory (  ).
- Press ok key to open menu.
-  Create a new contact.  Display all contacts in your local directory.  Delete the selected contact.  Delete all contacts in the local directory.

### Calling by number

Use one of the following:



- Lift the receiver and press the on-hook/off-hook key (on the Bluetooth handset), the handsfree key or a line key (  /  /  ). Dial the number.
- Dial the number directly and press:  /  OR  .

### Calling by name



- Enter the first letters of the surname and/or firstname (or full name), or the initials of the surname and/or firstname.
-  Press the search key or the OK key to start the search by name.
-  Start the call.

### Call from call log





When on the Homepage

- Using the up and down navigator (if necessary), find the contact to call.
- Press the callback key of the call log (grey for answered calls, red for unanswered calls)  /  .





### Make a call using the local directory

- Use the right navigation key to open your local directory (  ).
-  To quickly find a favorite contact when required.
-  Call the contact by pressing the call icon key.

### Answer a call

- Lift the receiver or use an answer keys  /  /  /  /  .





### Reject or deflect an incoming call

-  OR  Reject the call. The incoming call is ended.
-  Deflect the call to another contact:
-  Deflect the call to your voicemail.
-  Deflect the call to the personal assistant.

### Redialing

-  Redialing the last number dialed (redial).

### Placing a call on hold

-  The call is placed on hold (  ).
-  Recover the call on hold. You can resume the conversation (  ).



### Sending DTMF signals

- Sending DTMF is subject to configuration. Contact your administrator to check that the feature is enabled.
- Enter DTMF code.



### Mute, so that your caller cannot hear you

-  Disable microphone  The mute key blinks.



### Making a second call during a conversation

-  Press the key associated with the icon: *New call*.
- Call your contact using the dial by name or the dial a number feature.
-  Press the call icon key.
-  The first call is on hold.

### To cancel your second call and recover the first:





-  Hang up.
-  Press the key associated with the icon: *Retrieve*.
-  You are on the line with your first contact.

### Answering a second call during a conversation



-  Press the 'take the call' key.
-  The first call is on hold.
- As long as the call is presented, you can also choose to deflect the call.

### Switching between calls (Broker call)



Use one of the following:

-  Press the blinking line key.
-  You can talk to the second caller and the first one is on hold.
- Using the left-right navigation keys, select the blinking 'call on hold' icon (  ).
-  Press the key associated with the icon: *Retrieve*.



### Transferring a call

- During a conversation.
-  Press the key associated with the icon: *Transfer to*.
- Call the recipient of the transfer using the dial a number or dial by name feature.
-  The transfer is done as soon as the call is started.



### Conference

- Call the first contact.
- Call the second contact.
-  Press the key associated with the icon: *Conference*
-  You are in conference mode.



### Route your calls to your voicemail

- Using the left-right navigator, select the routing and overflow profile configuration menu (  ).
- Press the keys associated with: *Routing*  *Voicemail*.
-  Your calls are routed to voicemail.

### Route your calls to another number



- Using the left-right navigator, select the routing and overflow profile configuration menu (  ).
- Press the keys associated with: *Routing*  *User*.
- Select the user to route the calls to using the dial a number or search by name feature.
-  Your calls are routed to the user.

### Route your calls to an office device





- Using the left-right navigator, select the routing and overflow profile configuration menu (  ).
- Press the keys associated with: *Routing*  *My office device*.
- Select the device to route the calls to by pressing the associated key.
-  Your calls are routed to the selected device.

### Overflow to a number or voicemail



Your phone allows you to use default types of overflow.

- Using the left-right navigator, select the routing and overflow profile configuration menu (  ).
- Press the keys associated with: *Overflow*  *My office device*  *Overflow*.

### Route your calls to a customized list of devices

- Using the left-right navigator, select the routing and overflow profile configuration menu (  ).
- Press the keys associated with: *Profile*  *Customized*.
- Select a device to route calls to by pressing the associated key or entering another device number (  ).
-  Your calls are routed to the selected device.

### Information about the phone

- Using the left-right navigator keys, select the settings menu (  ).
- Press the keys associated with: *Phone*  *User Info*.
-  The name and number of your phone are displayed.



### Consulting your voice mailbox

-  Press the messaging key.



### Adjust audio volume

-   Bluetooth® wireless handset.

### Selecting language

- Using the left-right navigator keys, select the settings menu (  ).
- Press the keys associated with: *Phone*  *Language*.
- Select the language of your choice.

### Adjusting the audio functions

- Using the left-right navigator keys, select the settings menu (  ).
- Press the keys associated with: *Phone*  *User Info*.
- Reject or deflect an incoming call.